

INSTRUCTION MANUAL

PREMIX UNIT AIR HEATER

TYPE XR10... 60

VERSION 3

Production from 2005-12

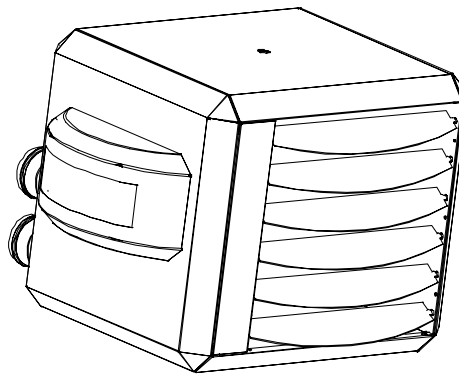
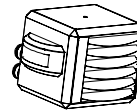

THIS DOCUMENT MUST ABSOLUTELY BE READ BEFORE STARTING THE
INSTALLATION.
INSTRUCT USER AND LEAVE THIS DOCUMENT WITH HEATER FOR
REFERENCE.

Instruction manual version GB 98b Argus
Heaters for GB
date: 07-07-2006
heaters for natural gas G20 and Propane

1 Introduction:

This installation and user manual is produced specifically for the gas, electrical and mechanical installer , it also gives instructions how to use and maintain the heater.

2 Content:

	Page
1 INTRODUCTION:	2
2 CONTENT:	2
3 GENERAL	3
3.1 GUARANTEE	3
4 APPLICATION RESTRICTIONS	3
4.1 PRE-CHECK	3
4.2 PROTECTION DEGREE	3
5 TECHNICAL DETAILS:	4
6.1 POSITIONING	5
6.2 GAS CONNECTION	5
6.3 ELECTRICAL CONNECTION	5
6.4 AIR INTAKE / COMBUSTION PRODUCTS DISCHARGE	6
7 FUNCTIONING OF THE UNIT	7
7.1 GENERAL	7
7.2 HEAT DEMAND	7
7.3 DELTA-T-REGULATION (TEMPERATURE CONTROLLED DE-STRATIFICATION FAN)	7
7.4 SUMMER VENTILATION	8
7.5 HIGH LIMIT PROTECTION	8
7.6 DESCRIPTION HEATER CONTROL HC	8
8 PUTTING INTO OPERATION AND ADJUSTMENT	9
8.1 GENERAL	9
8.2 START BY USING THE SERVICE-BUTTON	9
8.4 START BY USING THE THERMOSTAT	9
8.5 TO SIMULATE A LOCK OUT CONDITION	9
9 ADJUSTING THE GAS-CONTROL	10
10 PROBLEM SOLVING	11
10.1 GENERAL	11
11 MAINTENANCE / SPARE PARTS	13
11.1 GENERAL INSPECTION	13
11.2 INSPECTION OF THE HEATER	13
11.3 SPARE PARTS	13
12 EXAMPLES ELECTRICAL INSTALLATION	14
12.1 INSTALLATION WITH MODULATING ROOM THERMOSTAT	14
12.2 INSTALLATION OF MORE HEATERS ON ONE THERMOSTAT	14
12.3 INSTALLATION WITH ON/OFF THERMOSTAT	14
13 ELECTRICAL DIAGRAM	15

3 General

The premix unit air heater is provided with sophisticated control sequence to maintain a comfortable room temperature and even air distribution.

It is paramount that the installation and maintenance of this appliance are carried out by qualified gas engineers, and strictly according to our instructions.

3.1 Guarantee

The guarantee is invalidated when the air heaters are not installed in accordance with this manual.

4 Application restrictions



Important!

The installation and maintenance of this air heater should be performed by an authorized competent installer in accordance with this manual.

4.1 Pre-check

Before unpacking and installation, please check (i.e. on the data badge) if the heater is in accordance with the order and if it is suitable for the local present provisions (gas type, gas pressure, electrical supply etc.)

The Installation must comply with all applicable local and national standards.

The installation of the air heater must be in accordance with the relevant requirements of the Gas Safety regulations (for example in GB; The Institute of Gas Engineers IGE UP-1 and 2), building regulations and the IIE regulations also incorporating the gas safety (installation and use) regulations. Other national and/or local regulations may apply (the Local Authority ,Fire Officer and Insurers)

The competent installer must make sure the heater operates correctly and must instruct the user about the safe operation of the heater.

A ventilation gap of 30 cm is required from the top and bottom of the heater to any flammable materials.

If this heater is drawing its combustion air from within the room in where it is located, the necessary combustion ventilation requirements must be followed for gas safety regulations. The heater should not be installed in areas containing any corrosive or explosive vapours , in high moisture or dust concentrations, at negative pressures or temperatures higher than 30°C ; please consult Winterwarm or your supplier. The guarantee is then invalidated..

Make sure that the warm air can be blown out freely. There should absolutely be (no possibility of) materials within 5m from the front of the heater.

The heater has been tested in detail on safety and correct operating settings before leaving the factory. It has been adjusted for the type of gas that is stated on the data badge. Should there be any doubt , please contact the manufacturer.

4.2 Protection degree

The heater has a protection degree of IP20, this means for use in a dry and not very dusty environment. This is also the case for the Winterwarm room-thermostat.

5 Technical details:

Type		7(10)	7(20)	7(30)	7(40)	7(50)	7(60)
Maximum nominal heat input (Nett)	kW	14,0	22,8	32,0	44,0	55,0	66,0
Minimum nominal heat input (Nett)	kW	9,0	14,8	20,5	26,4	33,0	39,6
Maximum heat output	kW	12,8	20,8	29,2	40,2	49,9	60,5
Minimum heat output	kW	8,3	13,8	19,1	24,4	30,8	37,0
Max air output (+ temp increase)	m3/h	1150	2070	2600	4700	5150	6300
Throw horizontal (max)	m	12	16	23	26	28	30
Throw vertical (max. warm)	m	5	5	6	7	7	8
Sound level	dB(A)	42	45	45	46	47	49
Electric Connection	Vac	230	230	230	230	230	230
Thermostat communication bussystem (low voltage)		ja	ja	ja	ja	ja	ja
Power Consumption	W	250	250	250	450	450	600
Gas connection	G"	1/2"	1/2"	1/2"	3/4"	3/4"	3/4"
Minimum suspension height horizontal throw	m	1,7	1,7	1,7	2,7	2,7	2,7
Minimum suspension height vertical throw	m	4	4	4	5	6	6
Weight	kg	36	37	38	78	80	82

Natural gas G20, heater version 3.3; Torin DSB126-15 premix fan & metal plateburner

Min supply pressure	G20 (H)	mbar	20					
Gas category		Cat	I2H					
Class		Clas.	B23, C13, C33					
Max gas consumption	G20 (H)	m3/h	1,5	2,4	3,4	4,7	5,8	7,0
Offset gasvalve		mbar	-0,50	-0,60	-0,60	-0,25	-0,15	-0,15
CO2 max.	G20 (H)	%	9,0	9,0	9,0	9,0	9,0	8,9
CO2 min (indication)	G20 (H)	%	(7,6)	(7,7)	(8,5)	(8,2)	(8,2)	(8,3)

Propane G31, heater version 3.4; Torin DSB126-15 premix fan & metal fibreburner

Min supply pressure	G31(P)	mbar	37					
Gas category		Cat	I3P					
Class		Clas.	B23, C13, C33					
Max gas consumption	G31 (P)	kg/h	1,1	1,8	2,5	3,5	4,4	5,3
Offset gasvalve	(P)	mbar	-0,50	-0,60	-0,60	-0,20	-0,15	-0,15
CO2 max.	G31 (P)	%	10,8	10,7	10,7	10,7	10,7	10,5
CO2 min (indication)	G31 (P)	%	(9,8)	(9,7)	(9,9)	(10,9)	(10,3)	(9,9)

XR 10 - 30

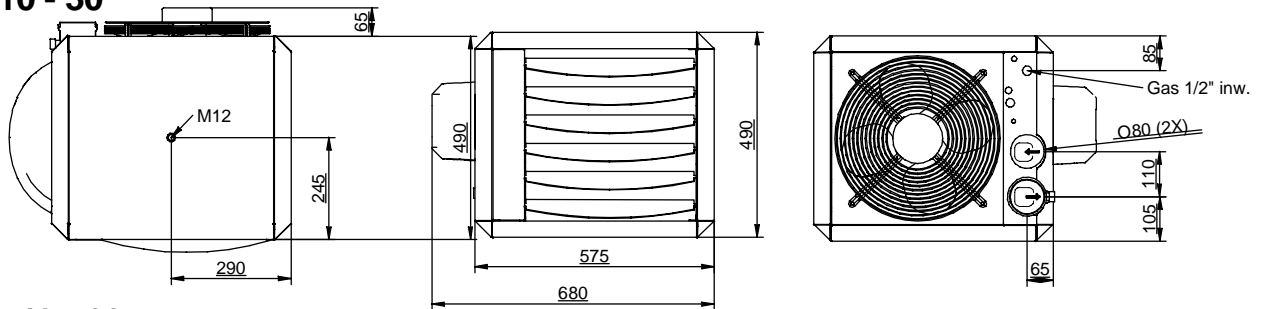

XR 40 - 60

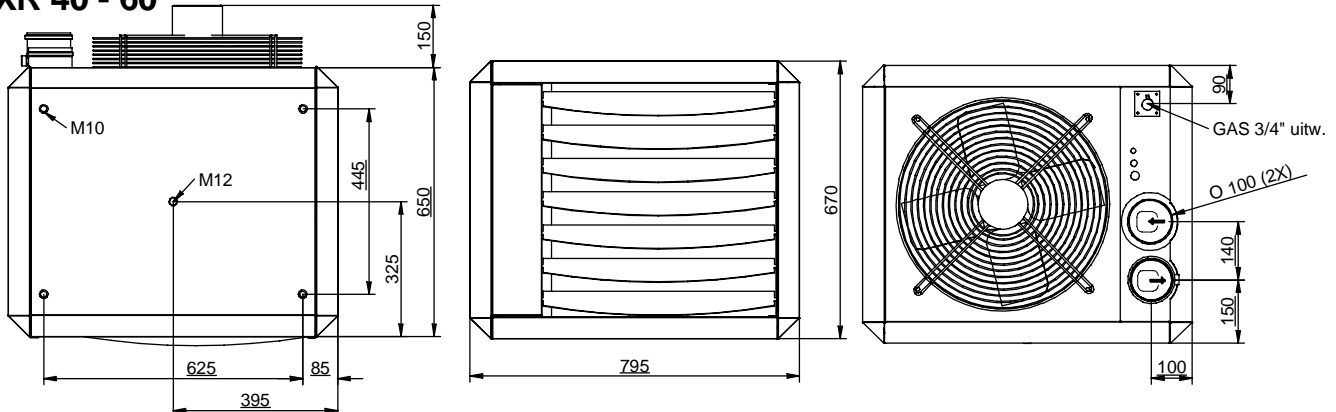

6 Installation

6.1 Positioning

- Check that the support is solid enough.
- Keep sufficient distance between the heater and any obstruction, in connection with safety and access for service and maintenance. Pay particular attention to any flammable materials. Please take into account the possibility to open the door of the heater for the necessary service and maintenance work. Make sure the air flow to and from the heater is unhindered. Any obstacles should be a minimum of 5 metres away from the front of the heater.
- The heater can be installed horizontally or vertically, the positioning is completely free.
- The heater is provided with 2 off M12 threaded sockets as fixing points (see the dimension diagram). The types 40, 50 and 60 also have four M10 threaded sockets on the top as fixing points. Use preferably the Winterwarm suspension kits.
- Make sure that after fitting, there is no mechanical tension on any connecting gas or electric supplies.
- If the heater is installed with the air stream vertical downwards the maximum suspension height is 8 meters. Otherwise the warm air will not reach the floor.

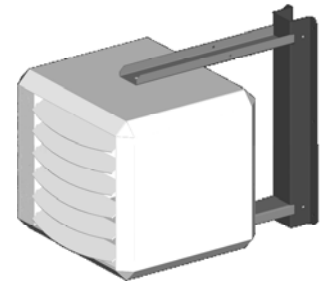
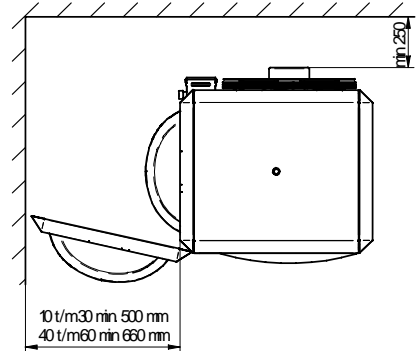

Attention:

See the application-restrictions in this manual (Chapter 4) for further installation restrictions.

6.2 Gas connection

The gas supply line has to meet the national valid requirements and possibly the local requirements of the building inspector, police or fire brigade. (In GB it must comply with Gas Engineers publication UP-1 and UP-2 together with BS 6891.

A manual isolation valve in the supply line must be placed within reach of the heater, and all gas lines must be mounted without any mechanical tension.

When testing the supply lines with pressures above 60 mbar, this manual valve at the heater must be closed.

The working and standing supply pressure must be a minimum of 17 mbar, and a maximum of 30 mbar, measured at the inlet pressure nipple of the gas control in the heater.

6.3 Electrical connection

6.3.1 230Vac supply

The installation must comply with local and national requirements, (as well as IEE regulations)

The unit heater is delivered completely wired internally, where controls of any type are to be added (e.g. room thermostat), the relevant wiring diagrams must be followed to. Never use a room thermostat to interrupt the electrical supply to the heater!

Make provisions to completely isolate the heater for maintenance purposes. This can be an isolation switch (min.3mm contact opening gap), a power plug or a non-switched fuse spur.

The wiring diagram for the heater can be found towards the end of this manual.

The supply is 230Vac. with earth. The control circuit is a two wire low voltage Argus-link bus communication.

6.3.2 Room thermostat

The heater can be controlled by a special Winterwarm room thermostat

The DB8; special designed digital clock thermostat with optimisimiser. It can control 1 to 8 air heaters..

De Multi Therm Standard; special designed digital thermostat. It can control 1 to 8 air heaters.

De Multi Control Unit; special designed interface module for connecting the air heaters with other appliances. (0-10V signal, On/OFF signal, high/low signal, reset and different outputs.

ON/OFF thermostat; The Heater can be controlled with a simple on/off thermostat. But then are some important functions not available, Like reset and modulation.

In all cases the communication between heater and thermostat is based on a two wire, low-voltage connection. In the appliance the wire for the thermostat has to be connected to connection 4 and 5 (see also electrical wiring diagram)



In all cases: make sure you use a screened low voltage cable.

In a EMCdisturbance sensitive environment a so-called sealed "twisted pair" cable must be used. Before connecting, switch off the tension from the heater. Connect the earth shield of the cable only to the earth terminal in the heater.

When mounting the thermostat, take attention to the following items:

- Mount the thermostat in a place where the air can circulate free pass the thermostat. Take notice that the sun does not shine directly upon the thermostat (in the winter). Do not place the thermostat on a cold wall. Place the thermostat on an inner wall free from draught.
- Never place the thermostat into the throw of the heater

6.3.3 Fuses

On the heater control HC there are two fuses. See electrical wiring diagram.

F1 and F2 are in the power supply of the heater. Replace the fuse only by a fuse of the same type.

6.4 Air intake / combustion products discharge

Check for compliance with local / national regulations.

The combined Winterwarm combustion-air supply / combustion-gas outlet device (Roof terminal or wall terminal) has to be used, only so the installation is CE approved. See installation drawings.

Never connect a roof terminal for condensing appliances, rain can damage the heater trough the discharge pipes.

Make sure the roof terminal is at least 0,5m above roof levelMaximum flue LengthUse only pipes and bends for overpressure with profiled sealing-rings.

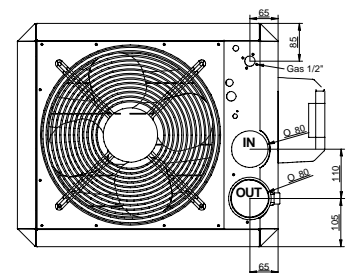

5.1.1

The maximum pressure drop in either the air supply pipe, or the flue pipe ,must not exceed 9 metres straight pipe , excluding the terminal. Whenever bends are used the pressure drop is greater and therefore a 90° bend will count as 2 metres and a 45° bend as 1 metre. All flue pipes must be of the same diameter as the flue spigots on the heater, and all flue joints must be sealed. For further information regarding the flue system please contact Winterwarm or your supplier

5.1.2 Condensation in the discharge system

During heating up, it is possible that condensate is formed in the discharge system. This, however, will evaporate if the heater is operating for a longer period of time.

If the straight length of the discharge flue is longer than 4 meters this condensate will not evaporate again and accumulate in the heater ! Isolation of the discharge pipes or an condensate trap just at the heater is then absolutely necessary.

The maximum flue length not isolated is 4 meters. (do not count bends)

The maximum flue length isolated is 9 meters. (do count bends, see below).

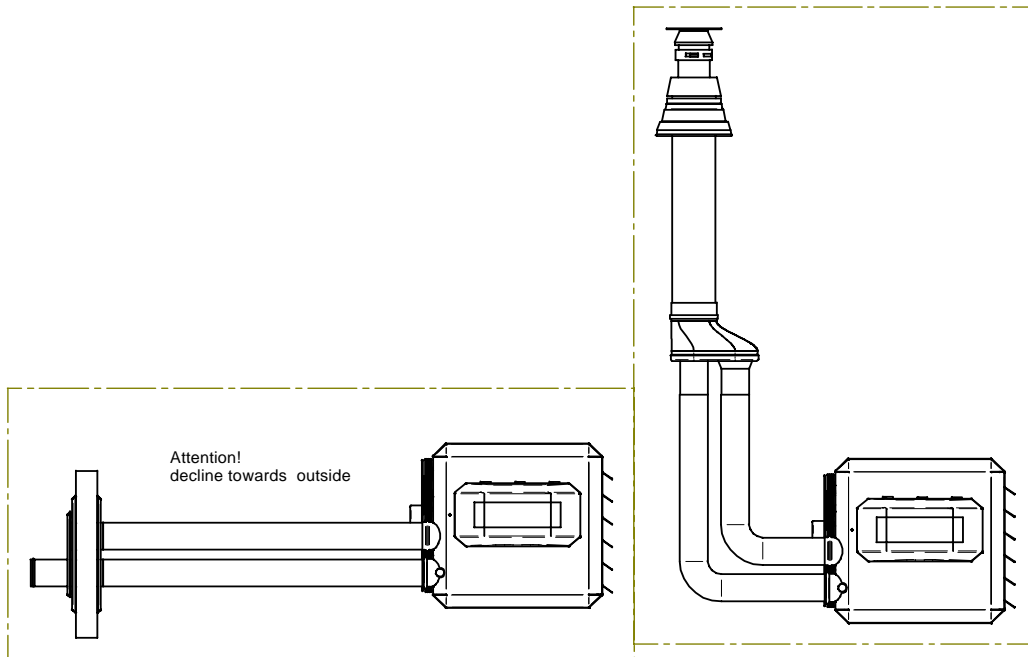

7 Functioning of the unit

7.1 General

The unit can heat as well as ventilate. By using the temperature-sensor on the unit and the one in the room-thermostat, the temperature-difference between the two in the room is monitored. Should the difference become higher than a set value, due to the fact that warm air has accumulated underneath the roof, the system-fan will start and push the warm air down, acting as a de-stratification fan.

7.2 Heat demand

If the thermostat indicates heat demand, the following cycle will commence:

1. **Pre purge:** The electronic circuit board acknowledges the heat-demand and the premix burner fan will start running for 30 seconds. Display print → 1
2. **Ignition:** After 30 seconds of pre purge the electrode will spark for max. 5 seconds, the gas valve is opened and the gas-air mixture will ignite. Display print → 2
3. **Burn:** When the flame is detected Display print → b. the unit will modulate to the desired load after ca. 15 seconds. Depending on the given load, the system fan will start modulating (step-less) as well. The air heater will **always burn for a minimum of 4 minutes**. This is to evaporate eventual condensate in the discharge system.
4. **End of heat demand:** When the heat demand ends, the burner will switch off and the system fan will continue to run for ca. 3 minutes in order to cool the unit down (Display print → P).

The unit will try to ignite twice before lockout on flame fault.

In the case of flame failure during operation, the heater will attempt one restart.

When the heater is in lockout you see in the display intermittent an A1. On the display of the room thermostat you see failure 1.

7.3 Delta-T-regulation (temperature controlled de-stratification fan)

In case there is no heat demand, the delta-T-regulation will be active.

When the temperature-difference between the sensor on the unit (the NTC) and the sensor in the thermostat is bigger than the set value (factory setting standard 8°C), the system fan will

start ,at a regulated speed, depending on the differential temperature difference. This operation ensures an even temperature distribution throughout the building, thus acting as a fully automatic variable de-stratification fan.

Should this delta-T-regulation not be required, in the Menu Program Settings on the room thermostat this regulation can be switched off. See user manual of the special Winterwarm Room thermostat.

7.4 Summer ventilation

It is possible to let the ventilator run on a certain speed in the summer. Please follow the instructions in the manual from the thermostat.

7.5 High limit protection

The unit contains 2 temperature protections. The NTC thermostat monitors the air temperature electronically. Should the temperature, in a first step, become too high, the burner will modulate to the minimum input and the system fan will modulate to the maximum speed.

When the temperature still increases, the burner will switch off (on display you see intermittent an E1). When the heat exchanger has been cooled to normal levels the burner will start automatically.

Should the temperature increase to an unacceptable level, , the heater stops (on display you see intermittent A2). Only after a manual reset the heater can start again. Manual reset can be done on the electronic circuit board or with the special Winterwarm Room thermostat

7.6 Description heater control HC

The heater control HC controls the unit and communicates with the room thermostat.

Functions integrated in the heater control HC are:

- two wire communication with room thermostat
- spark igniting on burner
- ionisation flame guard on burner
- controlling the gas valve
- modulating the premixed fan and burner
- modulating the system fan
- guarding the temperature of the heat exchanger
- LED signals status of heater, heat demand: green, failure: red
- Status of heater on 8 segment display on heater control HC
- reset of heater
- service mode function

Lay-out print board

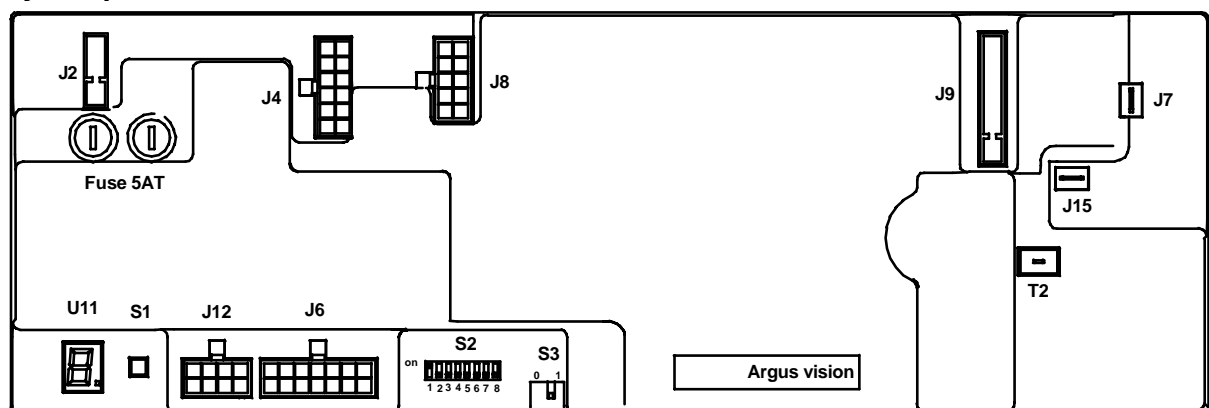

J2 Main power connection 230V

J4 Connection for gas valve and system fan

J6 Connection for room thermostat, appliance recognition and the status LED's green and red

J7 Earth burner

J8 Not used

J9 Premix- fan

J12 Connections for Temperature sensors

J15 Ionisation selector

F1 & F2 Fuses 2x 5AT

U11 Status display

S1 Reset service button

S2 Micro switch heater nr. Standard 1 to "on"

S3 Power supply thermostat when S2 nr1 to "on" then S3 op 1 else S3 to 0

T2 Ignition transformer, connection for ignitor

8 Putting into operation and adjustment

8.1 General

Prior to packaging, each unit is checked in detail on safety and well functioning. It is a.o. adjusted to the right efficiency of combustion. In general, the heater is not needed to be adjusted after installation, only a check of well functioning is necessary by a competent person. Also obtain a flue gas analysis and record it for later reference.

Use only a calibrated instrument !

The CO₂ value may be adjusted if necessary, only do this in case it turns out that the CO₂ value is not correct. Do not ever turn injudiciously the adjusting screws!

Adjustment of the gas control without a supporting flue gas analysis will invalidate the warranty.

Once the unit is installed according this manual, the unit can be put into operation. Make sure the gas pipe is clean, gastight and free from air.

Switch on the electric supply with the maintenance-switch, and open the door in order to be able to observe the first start-up and so become familiar with the functioning of the heater.

Should the gas line not be purged correctly the heater will attempt to start twice before going into a lock-out condition. Manual reset is necessary in that case.

Do not forget to instruct the end user about a safe use of the heater (presence of gas, place of the manual gas valve !), the operation of the heater (lock-out indication and reset) and about the necessary maintenance. This manual must be left with the end user.

8.2 Start by using the service-button

Press the service-button once for 10 seconds, and the unit will commence the ignition-cycle; (30 sec pre-purge, ignition, 15 sec flame stabilize, modulating operation) The burner will then start on minimum load Display print → L/b . By pressing the service-button again, the burner will go to maximum load.. Display print → H/b

Pressing the service-button for a third time will put the unit into normal operation. (depending if there is heat demand from the room thermostat).

8.4 Start by using the thermostat

Put the thermostat in the highest position. The start sequence is always the same as 8.2.

8.5 To simulate a lock out condition

Close the manual gas supply valve. The heater will go to lock-out after a restart attempt. The display on the electronic circuit board shows [**A 1**]. The red LED will light as well. Check also the function of the reset button (with gas valve open again), and observe if the heater starts smoothly.

Display on the printboard

0	stand-by	Stand-by
1	Pre-purge	System checks and 30 sec pre purge of the burner fan
2	Ignition	The ignitions electrode sparks 5 sec. and the gas valve opens, within 5 sec flame detection should occur.
b	Burn	After 15 sec stabilisation time, the heater will modulate to the desired power. The heater will remain burning minimum 4 minutes.
P	Post purge	The heater will cool the heat exchanger for 3 minutes, and the premix fan will post purge for 1 minute.
F	Summer ventilation	The system fan is running on the summer ventilation mode
F Blinking	Delta-T-regulation	The system fan is running on low position on Delta-T-regulation
L/1/2/... Blinking	Service Low	The heater is running on the service mode. When the heater burns, the heater will run on minimum power.
H/1/2/... Blinking	Service High	The heater is running on the service mode. When the heater burns, the heater will run on maximum power.

9 Adjusting the gas-control

In principle, it is **not** necessary to adjust the gas control after putting the unit into operation. In case it needs to be adjusted, (e.g. after fitting a new one), this must be done only by a qualified person. **Only use calibrated instruments !** A poor adjustment can lead to overheating and / or production of the poisonous carbon monoxide !.

There are two screws to adjust the gas control, the Offset adjuster and the Ratio adjuster.

Put the heater into operation at high fire by pressing the service button first 10 seconds and pres again shortly. You see on display H/b.

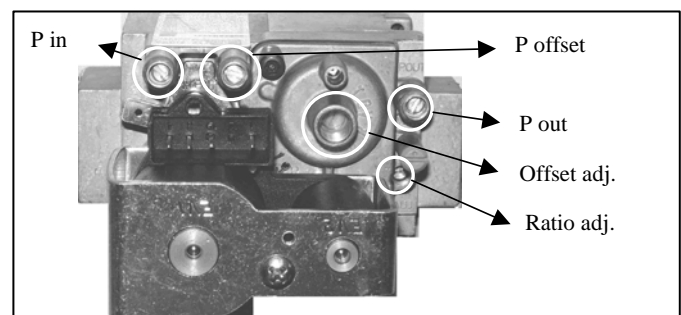

If the heater does not ignite while sparking, you can, if necessary, close the air-openings of the coloured ring on the gas-air mixer with thumb and forefinger during ignition. The mixture will become richer and will ignite more easily.

Open the pressure-nipple "P offset" and connect a calibrated pressure gauge to it. If the heater is in operation, the read under-pressure must comply with the value from the technical specifications. You can change this under-pressure by turning the Offset adjuster screw located under the little cover. Turn to the left for more under-pressure, turn to the right for less under-pressure. When the under-pressure is set correctly, you replace the little cover and close the pressure-nipple "P offset".

Check the CO₂ in high load of the heater. In case the CO₂ is too high, you turn the Ratio adjuster to the right (less gas). In case the CO₂ is too low, you turn the Ratio adjuster to the left (more gas).

Never forget to check the CO (carbon monoxide) production of the heater!!! Too much CO means mostly that the mixture is too rich. CO value should always be below 100 ppm. Always check and (adjust eventually) the CO2 content (see above), and then control the CO value.

After adjusting the high fire, the heater should be checked on low fire. (use service button)

10 Problem solving

10.1 General

When it turns out that the problem is **not** caused by the external circumstances (i.e. no electric supply power or no gas), please take the following instructions into account. Please remember the built in waiting times of the heater (do not react too soon!) and the signals of the LEDs and the code on the display on the electronic circuit board.

To simplify the investigation of the failing heater please check first:

- Check the fuses as well as the wires and plugs in the heater for possible loose contacts.
- In a heat-demand situation, the green LED on the heater must light up.
- In a flame failure situation, the red LED on the heater must light up, if so, reset.
- Use first the service-button to put the heater in run mode, try later the room thermostat.

Volatile lock out Can only be reset by hand

A0 Blinking	Internal failure	Print board defective
A1 Blinking	No Flame	Within 5 sec flame, then flame failure: Case 1: No flame: Case 2
A2 Blinking	Exchanger too hot	Heater stops on temperature heat exchanger too hot. Case 3
A3 Blinking	Sensor error	Temperature sensor on heat exchanger error. Case 4
A4 Blinking	Too many flame failures	Too many flame failures on ionisation; Case 1, 5
A5 Blinking	Internal error	Print board defective
A6 Blinking	Safety relays	2 ^e temperature limiter (optional) switched Case 3, 10
A7 Blinking	Flame	Flame detection when there should not be a flame
A8 Blinking	Burner fan	Burner fan dos not run; Case 6 Burner fan runs; Case 7

Non volatile lockout

Will disappear when the error is cleared.

E/0 blinking	Internal defect	Print board defective
E/1 blinking	1 ^e temperature safety	Heater stops on temperature heat exchanger too hot. When heater is cooled down the heater will restart. Case 3
E/2 Blinking	Selection resistance	Heater recognition does not work Case 8
E/3 blinking	Selection resistance	Heater recognition does not work Case 8
E/9 blinking	Reset error	Too many switches on reset button Case 9

Case 1: Within 5 sec flame, then flame failure.

- The flame is not detected. Check the ignition cable and electrode.
- The heaters has electrically a poor earth.
- The print board is defective.

Case 2:

- There is not enough gas pressure.
- The mixture of gas/air is poor, adjust the gas valve
- The gas valve does not open, check during ignition on 230V on the valve.
- Check whether the ignition electrode sparks, replace cable, electrode

Case 3: Heat exchanger too hot

- Check whether the system fan blows enough air.
- Check the setting of the gas valve, the heater may be overloaded.

Case 4: Temperature sensor on heat exchanger error.

- The sensor has internally 2 sensors. These differ too much. Measure the resistance from each sensor, the resistance should be 20K at 25° en 25K at 20°. If the measured values differ too much, replace sensor.
- Rotate the sensor ¼ turn. So the contact point is different on the sensor housing.

Case 5: Too many flame failures while burning

- The setting of the gas valve is not ok, adjust the gas valve
- The flue outlet is blocked

Case 6: The premix does not run

- Premix fan is Blocked or the wiring is bad
- Premix fan is defective

Case 7: The pre-mix fan runs, but not the correct speed.

- Check if the fan runs smoothly.
- Check the wiring.

Case 8: Selection resistance error

- Check the appliance recognition part, replace if necessary

Case 9: Reset button error

- Too many switches on reset button in a short period of time. These error will disappear after some time, or if the main power is disconnected for a while.

Case 10: 2^e STB (optional) switched

- Heaters equipped with 2 system fans have a second temperature limiter. The second limiter has switched. Check the fan where this sensor is mounted..
- Check the wiring

Heater does start, but shows other problems.

a) The heat output of the heater will also be insufficient if there is too much resistance in the inlet- or outlet flue system. In this case the premix-burner-fan will be on full speed, but

because of the high resistance too little air is moved and therefore also too little gas. The pressure in the outlet flue for example, will normally never be above 30 Pascal.

- a) System fan (M1) does not start or does not vary in speed; Check first the functioning of this fan by connecting it to 230 Volt. Check with a multi-meter if the different lower tensions are secondary present on the transformer as well. The fuse could have failed. If the motor and transformer are OK, the cause of the problem must be in the heater control HC, as the heater control HC dictates the different voltages from the transformer to the fan-motor. In that case, replace the heater control HC.

11 Maintenance / spare parts

The heater must be inspected and cleaned regularly (once a year) by a qualified installer who understands this appliance.

This is all the more important as the circumstances are heavier, especially in case of dust, humidity, high frequency of switching on/off etc.

Activities:

11.1 General inspection

- Check the overall condition of the installation. Check the heater, the thermostat, the wires and the gas line.

11.2 Inspection of the heater

Before starting the inspection, switch off the electric power to the heater with the maintenance-switch and close the manual gas valve.

- Take out the burner, complete with flange and pre-mix fan, by unscrewing the 6 off M6 socket screws and you have taken off the ignition and fan wires
- Check the heat exchanger from the inside for dirt and/or damage.
- Check the burner on damage and clean the ignition electrode if necessary . CAUTION: do not twist the electrode out of shape!
- Check the air supply and the flue discharge.
- Clean eventual the inside of the heater with a vacuum cleaner.
- In case the heat exchanger is dirty on the outside, clean it with a soft brush. Never use a steel wire brush!
- Clean the fan-grid with a vacuum cleaner and a brush.
- Put the burner back in (renew the gasket)

After this, check the heater on efficiency of combustion and adjust these if necessary
Check the heater operates correctly.

11.3 Spare parts

Description	10	20	30	40	50	60	
Burner XR	IX.3206	IX.3206	IX.3208	IX.3208	IX.3210	IX.3212	
Ignition/Ionisation electrode	IX.3458	IX.3458	IX.3458	IX.3458	IX.3458	IX.3458	
Premix fan Torin DSB126-15	IX.4522	IX.4522	IX.4522	IX.4522	IX.4522	IX.4522	version 3.3&3.4
Inspection glass	IX.6812	IX.6812	IX.6812	IX.6812	IX.6812	IX.6812	
Gas control SIT SIGMA 848	IX.3000	IX.3000	IX.3000	IX.3000	IX.3000	IX.3000	
System fan FMV (M1)	IX.4200	IX.4200	IX.4200	IH.4206	IH.4206	IX.4205	
NTC Cable sensor	IX.3918	IX.3918	IX.3918	IX.3918	IX.3918	IX.3918	
Gasket ; inlet heat exchanger	IX.6702	IX.6702	IX.6702	IX.6742	IX.6742	IX.6742	
Gasket ; outlet heat exchanger	IX.6708	IX.6708	IX.6708	IX.6744	IX.6744	IX.6744	
Gasket ; premix fan	IX.6704	IX.6704	IX.6704	IX.6704	IX.6704	IX.6704	
Gasket ; ignition / ionisation electr	IX.6710	IX.6710	IX.6710	IX.6710	IX.6710	IX.6710	
Gasket ; inspection glass	IX.6706	IX.6706	IX.6706	IX.6706	IX.6706	IX.6706	
Burner isolation plate	IX.6720	IX.6720	IX.6720	IX.6724	IX.6724	IX.6724	

12 Examples electrical installation

12.1 Installation with modulating room thermostat

- Connect the heater to 230Vac
- Connect the thermostat to the terminals according to the diagram. (terminal 4 and 5)

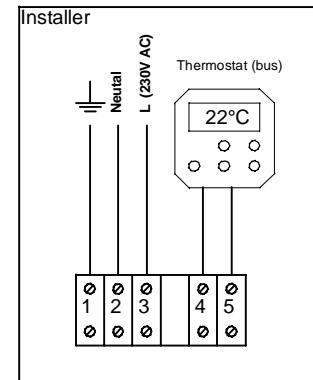

12.2 Installation of more heaters on one thermostat

One room thermostat can control 8 heaters. To connect the heaters is very simple. The two wires for the thermostat can be connected to heater one, from heater one to heater two, from heater two to heater three etc. etc. Connect always on terminal 4 and 5. See also the diagram.



Standard factory setting: switch 1 "on"

Each heater needs his own unique number to recognise the heater by the room thermostat. The number of the heater can be set by the micro switch on the heater control HC in the heater. The number at the upper position of the switch is the given number for that heater. Make sure that each heater has its own unique number. If more than one heater have the same number the system does not work.

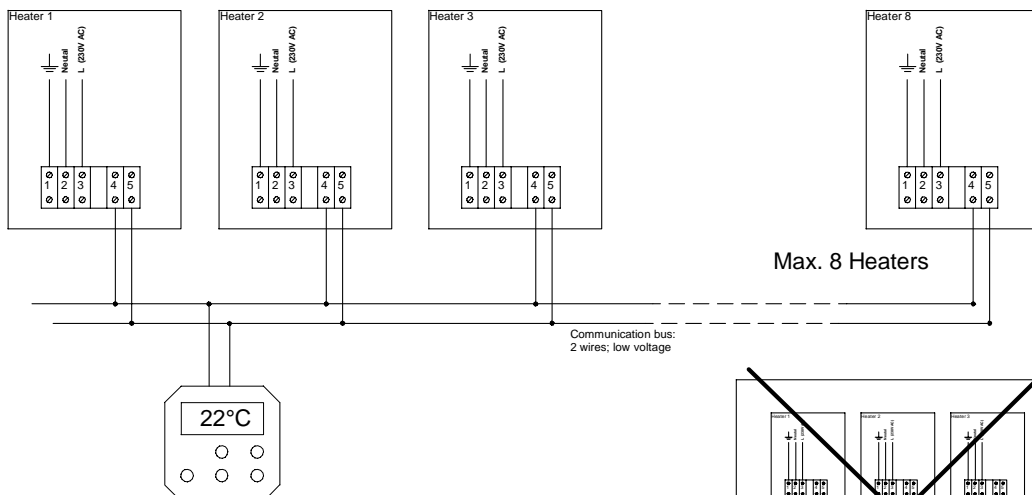

in heaters:
micro switch on printboard.

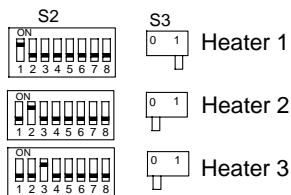

Important:

When more heaters on one thermostat, each next heater must have its own number (2 til 8). Only in heater nr 1 S3 to ON, other heaters S3 to 0. Do not change clamp 4 with 5 between the heaters.

12.3 Installation with ON/OFF Thermostat

The heater can be connected to an ON/OFF thermostat.

In this case, the heater runs on maximum power only. It will not modulate.

The manual reset in case of fan error will have to be done with the reset button on the main board.

The following settings have to be made on the main board in the heater:

- The micro switches on the main board have to be set to OFF, see example.
- The switch S3 has to be set to 1.
- The thermostat has to be connected to the clamps 4 and 5 in the heater.
- In the case that more than 1 heater is connected to 1 thermostat, do not exchange clamp 4 with clamp 5 between the heaters. This will result in permanent burning of the heaters.

13 Electrical diagram

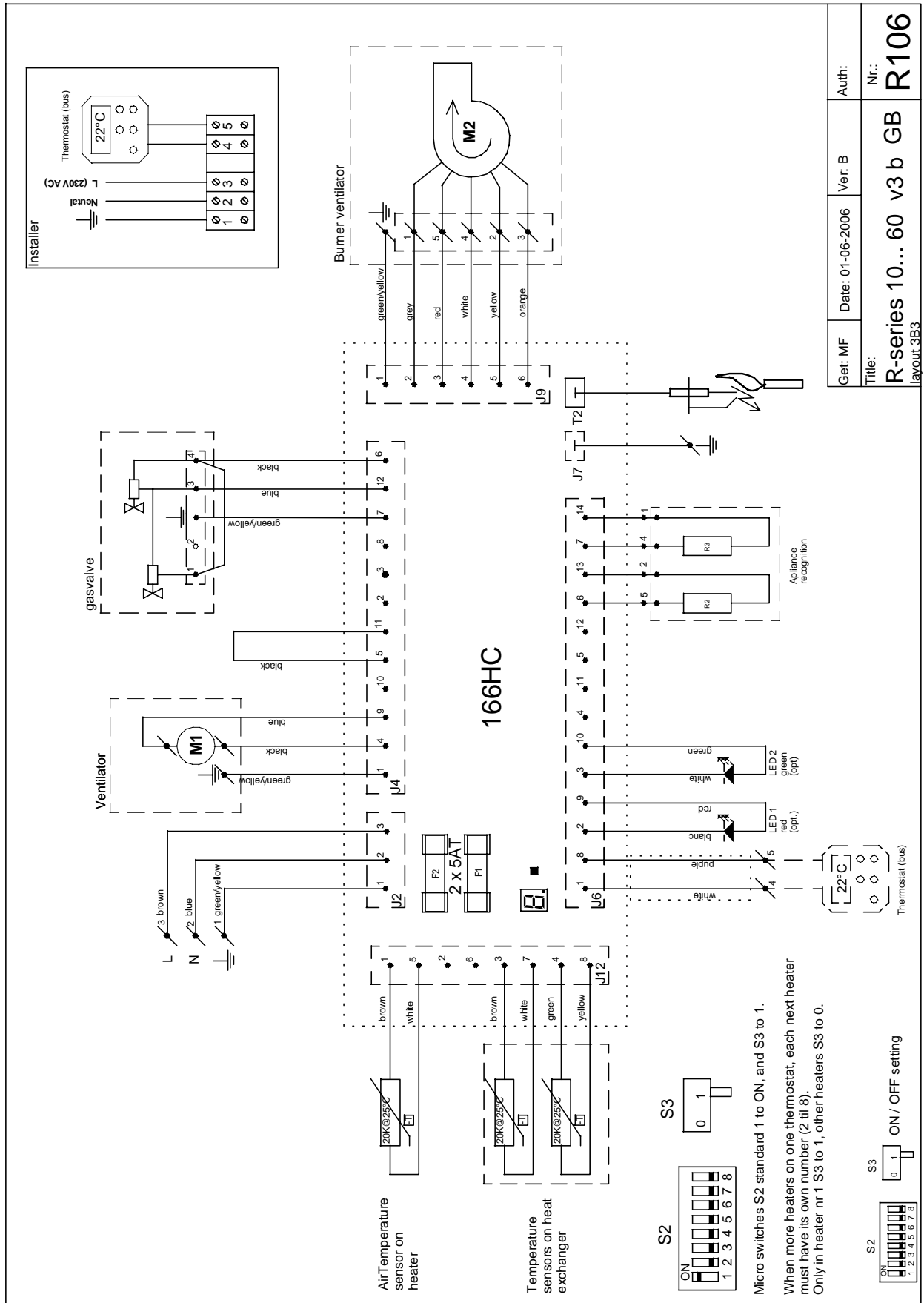

Get: MF	Date: 01-06-2006	Ver: B	Auth:
Title: R-series 10... 60 v3 b GB			Nr.: R106
layout_3B3			

Micro switches S2 standard 1 to ON, and S3 to 1.
 When more heaters on one thermostat, each next heater must have its own number (2 till 8).
 Only in heater nr 1 S3 to 1, other heaters S3 to 0.